

MSI

Making Dream Surfaces Attainable

AcquaLuxe™ FAUCETS

LAVATORY FAUCET

Specification of Item NO.#FAU-B2HBN4201-405

FEATURES

Washerless Cartridge • Metal Lever Handle

Max Flow Rate: 1.2GPM(4.5LPM) at 60 PSI (ASME.A112.18.1M)

Finish: Brush Nickel Finish

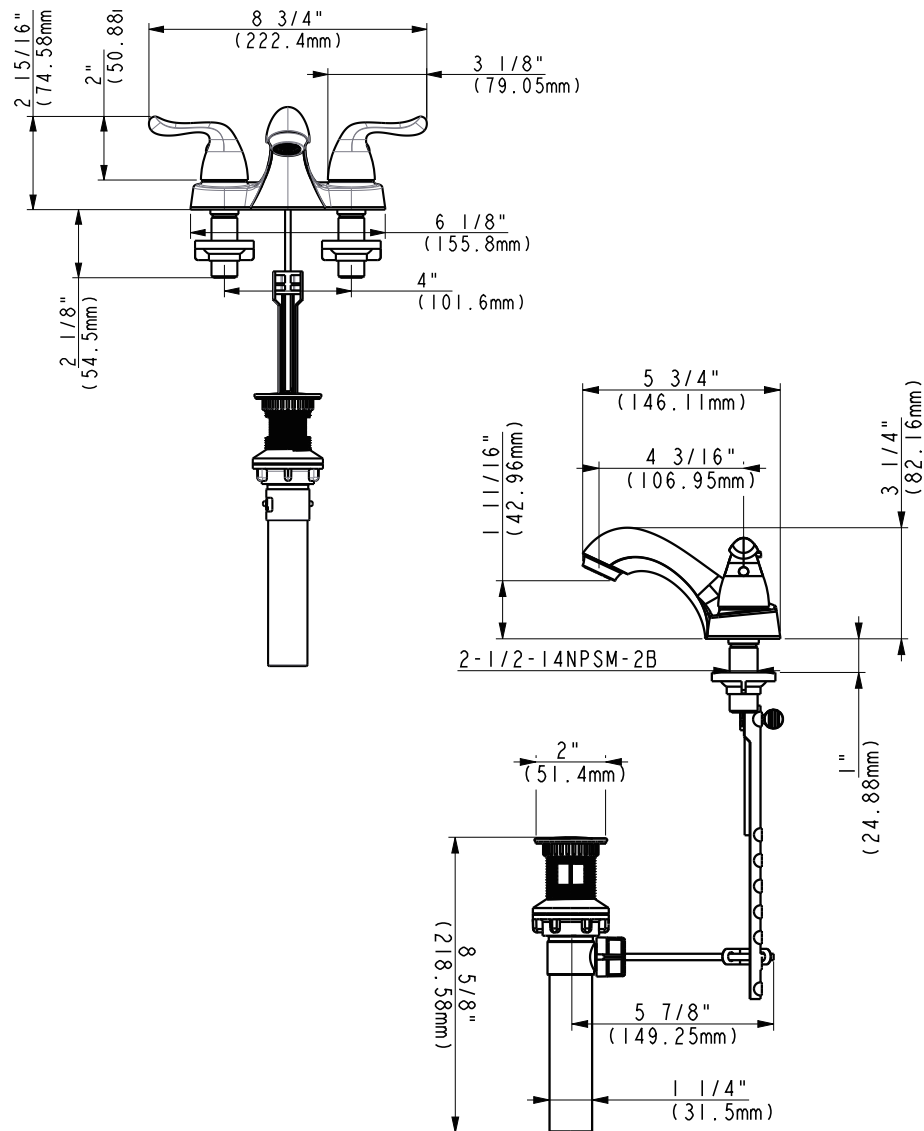

APPROVAL: Meets or exceeds the following: *ANSI/ASME A112.18.1m, *ANSI/NSF 61-Sec.9, *IAPMO/CUPC