

# MSI

Making Dream Surfaces Attainable

## AcquaLuxe™ FAUCETS

### LAVATORY FAUCET

Specification of Item NO.#FAU-B2HCR4206-410

#### FEATURES

Ceramic Cartridge • Metal Lever Handle

**Max Flow Rate:** 1.2GPM(4.5LPM) at 60 PSI (ASME.A112.18.1M)

**Finish:** Chrome finish

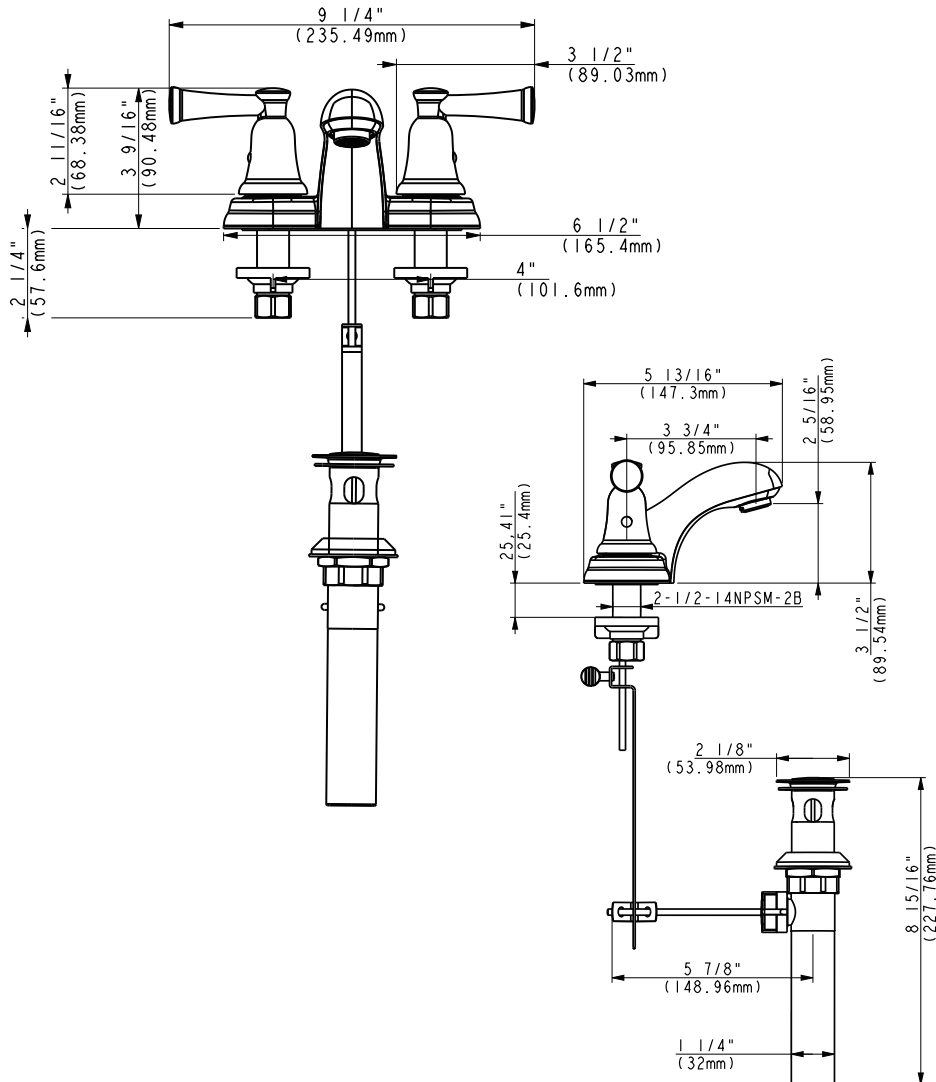

**APPROVAL:** Meets or exceeds the following: \*ANSI/ASME A112.18.1m, \*ANSI/NSF 61-Sec.g, \*IAPMO/CUPC