

MSI

Making Dream Surfaces Attainable

AcquaLuxe™ FAUCETS

KITCHEN FAUCET

Specification of Item NO.#FAU-K1HBN8401-803

FEATURES

Ceramic Cartridge • Metal Lever Handle

Max Flow Rate: 1.8GPM(6.8LPM) at 60PSI (ASME.A112.18.1M)

Finish: Brush Nickel Finish

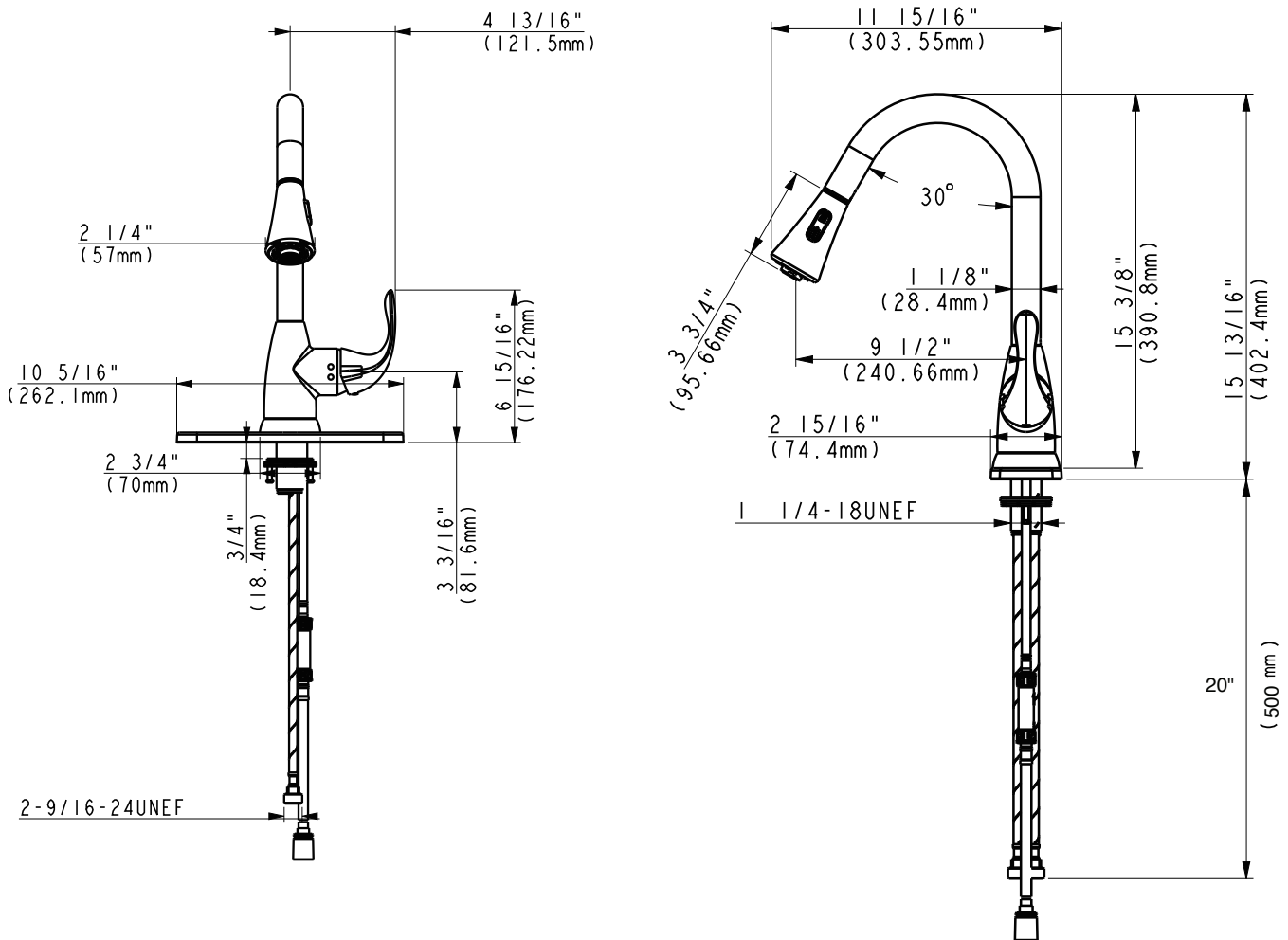

APPROVAL: Meets or exceeds the following: *ANSI/ASME A112.18.1m, *ANSI/NSF 61-Sec.g, *IAPMO/CUPC